



WALLWASHER LIGHT

Simple and easy appearance, in line with contemporary aesthetic concept. The product has the structure and appearance design patent. The lamp body adopts high-pressure cast aluminum and aluminum alloy, the surface is coated with outdoor used powder, double anti-corrosion to extend service life. This lawn lamp series uses LED. High efficiency constant current driver, ensure the light source is maximum used.

IEC 62717 LED-modules for general lighting – Performance requirements
IEC 62722-2-1 Particular requirements for LED luminaires

High Lumen Efficacy - 110lm/W
Housing die cast aluminum
Glowing Wire Test - 850°
Temperature - ta=20 °C ~ ta max=50 °C
Class - III

FIELDS OF APPLICATION

All outdoor areas

Model --- Q27

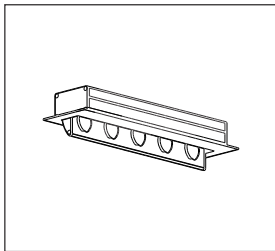

- A** - L343 x W92 x H72
Cutout - L315 x W80mm
- B** - L643 x W92 x H72
Cutout - L615 x W80mm

Default Available

30Q27-B-30-48-0-A

Product Assistant Chart

Q27		X	X	X	X	X			
Size	A	B						[]	[]
Driver	0	1	2	3	4			[]	
	On/Off	Dali	Dimmable	Phase Dimming	0-10			[]	
Beam Angle	12°	24°	48°				[]	[]	
Kelvin	30	40	60	RGB/W		[]			
	3000K	4000K	6000K	RGB/W		[]			
Finishing	W	G	B					[]	
	White	Dark Grey	Black					[]	
Wattage	5 X 3W	10 X 3W						[]	[]

Lighting Customization Solution offer the wide range of customized product with best available options.

IP 20 IK 06 LED McA Step 3 110~240V

Relative spectral perception of brightness and melanopic effect

Effect as a percentage

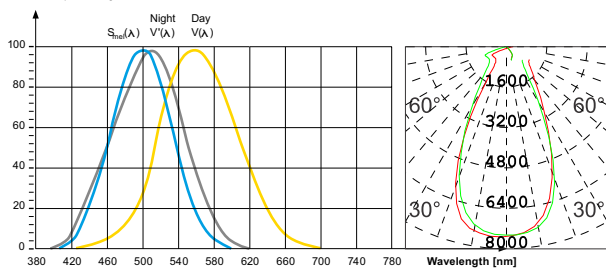

Explanation of the three curves:
V(A) = Perception of brightness, daytime seeing with the cones
V(A) = Night-time seeing with the rods
S_m(A) = Melatonin suppression with the photosensitive ganglion cells

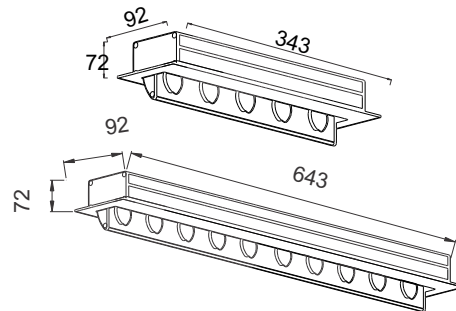
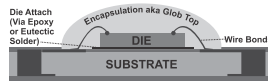
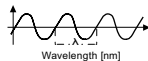

LED life time		Operating time 1.000 h										
Lamp Lumen Maintenance Factor		1	10	20	30	40	50	60	70	80	90	100
Lamp Survival Factor		1	1	1	1	1	1	1	1	0.99	0.99	0.99
L80	50.000 h	LLMF	1	0.96	0.92	0.88	0.84	0.80	0.76	0.72	0.68	0.64
		LSF	1	1	1	1	1	1	0.99	0.99	0.99	0.98
L80	100.000 h	LLMF	1	0.98	0.96	0.94	0.92	0.90	0.88	0.86	0.84	0.82
		LSF	1	1	1	1	1	1	1	0.99	0.99	0.99



LED



series wiring



CE



LM-80



FLICKER FREE