



Pole Light

Simple and easy appearance, in line with contemporary aesthetic concept. The product has the structure and appearance design patent. The lamp body adopts high-pressure cast aluminum and aluminum alloy, the surface is coated with outdoor used powder, double anti-corrosion to extend service life. This lawn lamp series uses LED. High efficiency constant current driver, ensure the light source is maximum used. Homogenous symmetrical or asymmetrical lighting distribution. Hot dip galvanized corrosion resistant (TSE) pole.

IEC 62717 LED-modules for general lighting – Performance requirements  
IEC 62722-2-1 Particular requirements for LED luminaires

High Lumen Efficacy 120lm/W  
Body - Corrosion resistant aluminum  
Diffuser - Tempered Glass  
Glowing Wire Test - 850°  
Temperature - ta=-20 °C ~ ta max=65 °C  
Class - I

**FIELDS OF APPLICATION**

Outdoor Gardens, Parks, Pathways,

Model --- **R46**

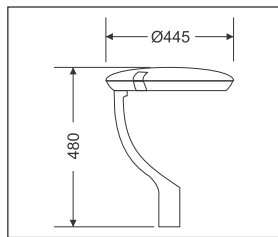

Head- Ø445 X 480Hmm

Default Available



Product Assistant Chart

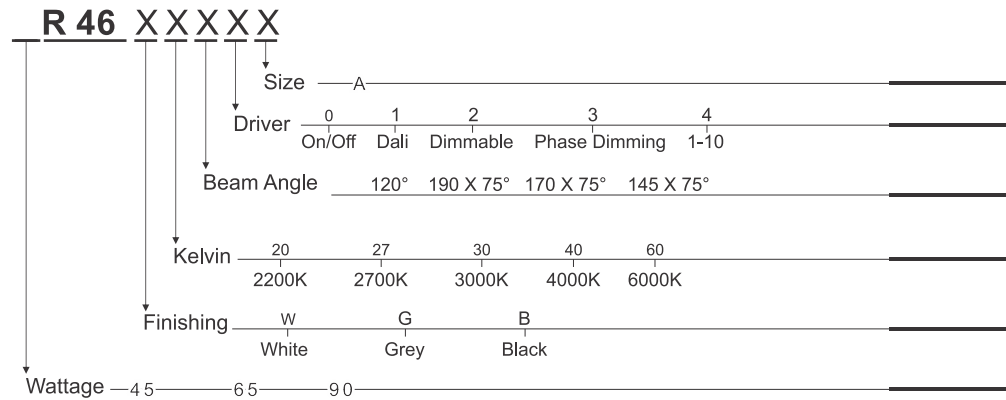

Lighting Customization Solution can offer you modifications for environment with higher options as a customized product.

IP 65    IK 10    SMD    McA Step 3    220-240VAC

**Relative spectral perception of brightness and melanopic effect**  
Effect as a percentage

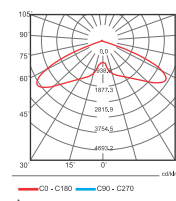
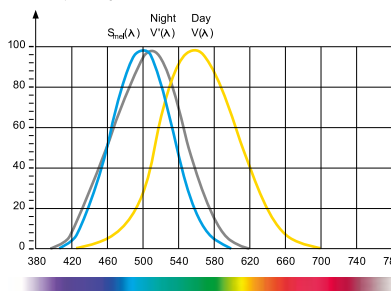

Explanation of the three curves:  
V(A) = Perception of brightness, daytime seeing with the cones  
V(A) = Night-time seeing with the rods  
S<sub>m</sub>(A) = Melatonin suppression with the photosensitive ganglion cells

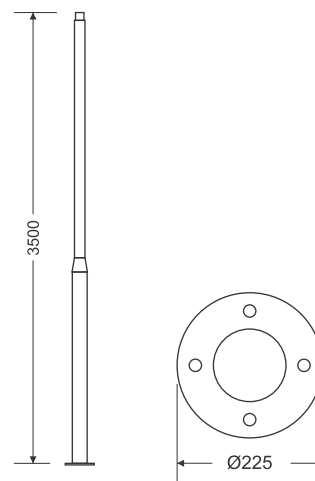
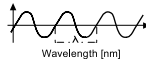

LED life time		Operating time 1.000 h										
Lamp Lumen Maintenance Factor	Lamp Survival Factor	1	10	20	30	40	50	60	70	80	90	100
L80	50.000 h	LLMF	1	0.96	0.92	0.88	0.84	0.80	0.76	0.72	0.68	0.64
		LSF	1	1	1	1	1	1	0.99	0.99	0.99	0.98
L80	100.000 h	LLMF	1	0.98	0.96	0.94	0.92	0.90	0.88	0.86	0.84	0.82
		LSF	1	1	1	1	1	1	1	0.99	0.99	0.99

