



Bollard Light

Simple and easy appearance, in line with contemporary aesthetic concept. The product has the structure and appearance design patent. The lamp body adopts stainless steel outdoor used anti-corrosion to extend service life. This range uses LED. High efficiency constant current driver, ensure the light source is maximum used. Homogenous symmetrical or asymmetrical lighting distribution

IEC 62717 LED-modules for general lighting – Performance requirements
IEC 62722-2-1 Particular requirements for LED luminaires

High Lumen Efficacy 140lm/W
Body - Stainless Steel
Diffuser - Polycarbonate
Glowing Wire Test - 850°
Temperature - ta=-20 °C ~ ta max=65 °C
Class - I

FIELDS OF APPLICATION

Outdoor Gardens, Parks, Pathways,

Model --- **R 52**

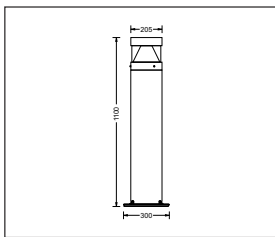

A - Ø205 x 1100H

Default Available

25R52-SS-30-360-0-A

Product Assistant Chart

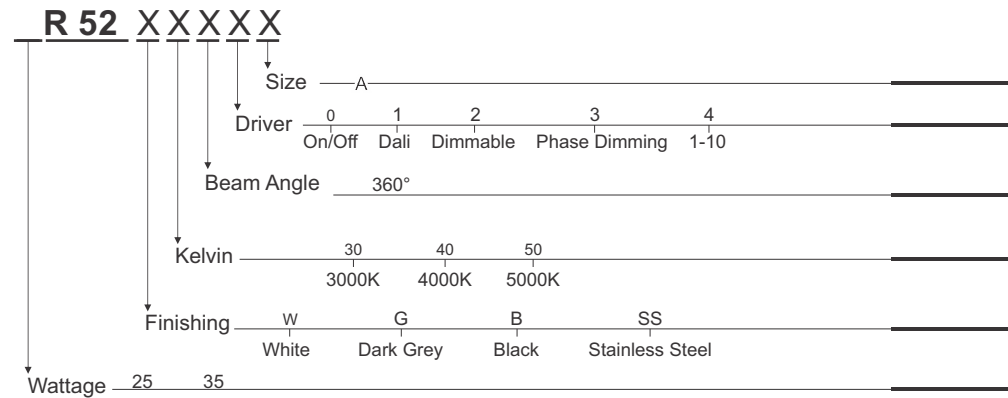

Lighting Customization Solution can offer you modifications for environment with higher options as a customized product.

IP 65 IK 10 LED McA Step 3 100~240V

Relative spectral perception of brightness and melanopic effect

Effect as a percentage

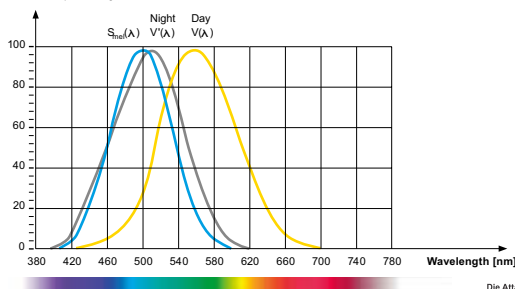

Explanation of the three curves:
V(A) = Perception of brightness, daytime seeing with the cones
V(A) = Night-time seeing with the rods
S_m(A) = Melatonin suppression with the photosensitive ganglion cells

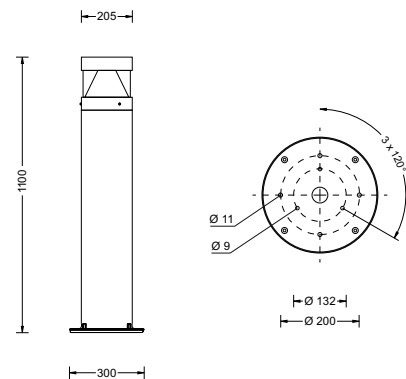
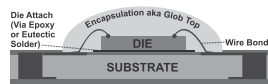
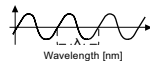

LED life time		Operating time 1.000 h										
Lamp Lumen Maintenance Factor	Lamp Survival Factor	1	10	20	30	40	50	60	70	80	90	100
L80	50.000 h	LLMF	1	0.96	0.92	0.88	0.84	0.80	0.76	0.72	0.68	0.64
		LSF	1	1	1	1	1	1	0.99	0.99	0.99	0.98
L80	100.000 h	LLMF	1	0.98	0.96	0.94	0.92	0.90	0.88	0.86	0.84	0.82
		LSF	1	1	1	1	1	1	1	0.99	0.99	0.99



LED



series wiring

